

G5.1

VEGETABLE CUTTER GASTRONOMY / CANTEENS

At a glance:

- XXL feed chute (cross-section 173 cm²)
- Diagonal cutting
- Functional space for 1/1 GN-containers
- Basic unit and components made of stainless steel
- Fully adjustable speed regulation
- Basic carrier disk
- Removable dishwasher suitable functional components
- Automatic switch off



Functional space for 1/1 GN-containers
(Height 150 mm)

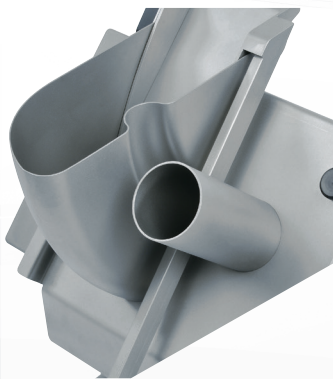

Filler neck for elongated material (dia. 59 mm)

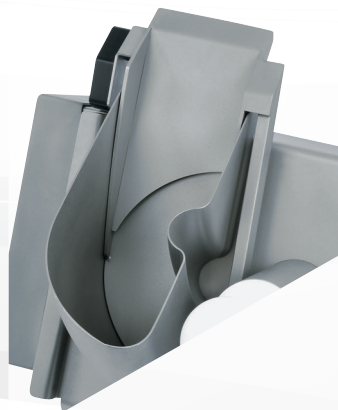

XXL filling chute as depot for processing large volumes in one step (Cross-sectional area 173 cm²)



Easy cleaning by removal of the cutting lid, dishwasher-safe



Infinitely variable setting from 130 to 360 rpm

Safety catch at the side to latch the filler flap in place

Accessories

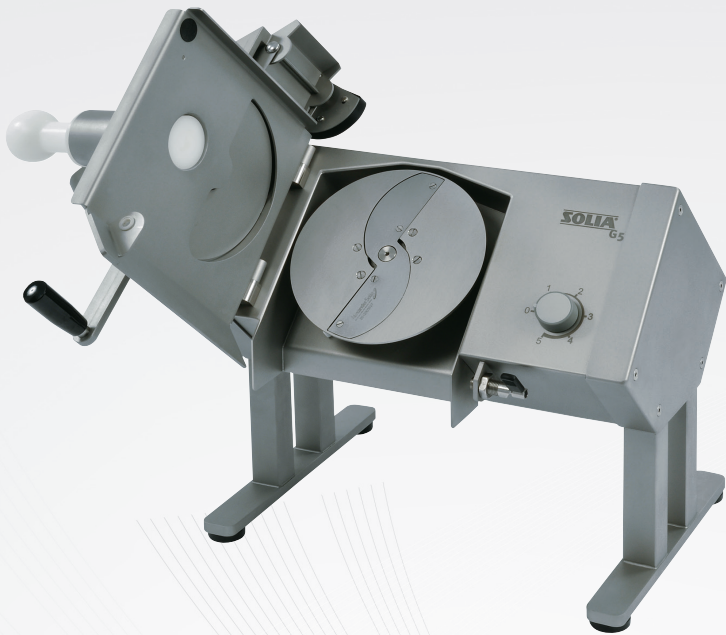

Diagonal cutting hopper
to be placed on the feed chute, with safety switch-off and pusher

105 070 020

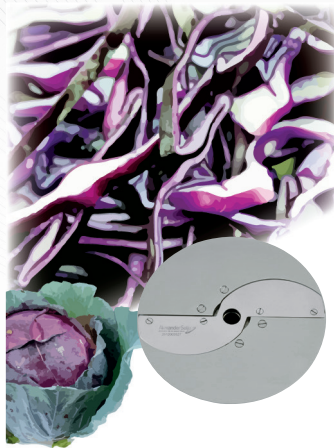

Curved blade disc, stainless steel, adjustable double-blade
0 - 5 mm 561 000 0352*

Cutting e.g. cabbage, cucumbers, pepper, onions

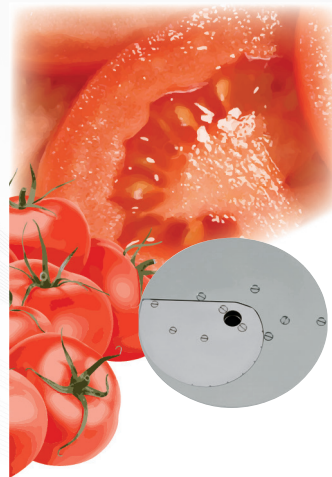

Curved blade disc, stainless steel, adjustable single-blade
0 - 10 mm 103 275 000

Cutting soft vegetables



Crescent blade discs, stainless steel
3 mm 561 000 0363
4 mm 561 000 0360*
6 mm 561 000 0361

Cutting of boiled potatoes, leek, mushrooms, soft fruits



Strip cutting discs, stainless steel
2 x 2 mm Juliennes 561 000 0362*
4 x 4 mm Juliennes 561 000 0364
6 x 6 mm 561 000 0366
8 x 8 mm 561 000 0368

Strip cutting of carrots, celery, radishes



Crinkle cutting discs, stainless steel
4 mm 561 000 0369
6 mm 561 000 0367

Crinkle cut of red beets, cucumbers, carrots

Accessories



Basic carrier disc, stainless steel for:

- raw vegetable discs,
- shredding discs,
- grating discs,
- potato grating disc,
- potato pancake disc

568 000 0370*



Raw vegetables discs, stainless steel, hand sharpened

2 mm	561 000 0380
2,5 mm	561 000 0382
3 mm	561 000 0371*
4 mm	561 000 0374

Shredding of raw vegetables e.g. celery, radish, potatoes, carrots, parmesan, carrots



Shredding discs, stainless steel, hand sharpened

6 mm	561 000 0372*
9 mm	561 000 0373

Shredding of vegetables e.g. celery, radish, potatoes, Gouda



Grating discs, stainless steel

2 mm	561 000 0381
3 mm	561 000 0375
4 mm	561 000 0378

Grating e.g. bread, nuts, almonds, chocolates, cheese



Potato grating disc, stainless steel, crown-toothed

561 000 0376

Grating e.g. potatoes, parmesan cheese



Potato pancake disc, stainless steel, partly crown-toothed, combination of 376 / 380

561 000 0377

Grating e.g. potatoes



Dicer complete, stainless steel

4 x 4 x 5 mm	105 040 100
5,5 x 5,5 x 5 mm	105 043 100
8 x 8 x 10 mm	105 046 100
11 x 11 x 10 mm	105 049 100*
16 x 16 x 10 mm	105 052 100
22 x 22 x 10 mm	105 055 100



Protective hand grip for dicer disc

105 040 190

Cleaning brush

1500876

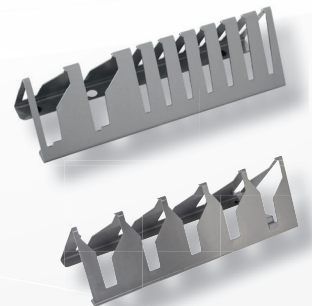

Multi disc rack, stainless steel, for 2 discs and 7 exchange discs

561 000 0191*

Disc rack, stainless steel, for 5 discs

561 000 0190

Technical data

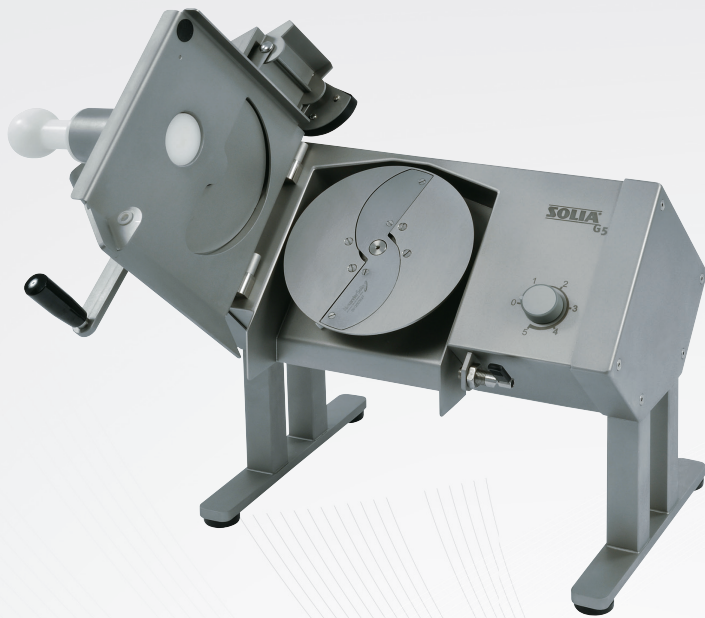

Technical data

Power supply	230 V, 50 Hz 2,5 m cable with two pin earthed plug
Output (kW)	0,37
Fuse protection (A)	16
Ingress protection	IP 54 (splash-proof)
Infinitely variable speed control (rpm)	130- 360 (variable)
Dimensions (L x W x H)	474 x 432 x 520 mm (max. 850 mm)
Weight (kg)	28

G 5.1 vegetable cutter

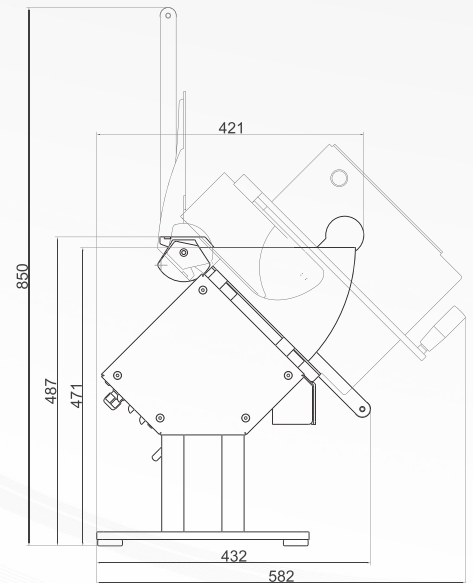
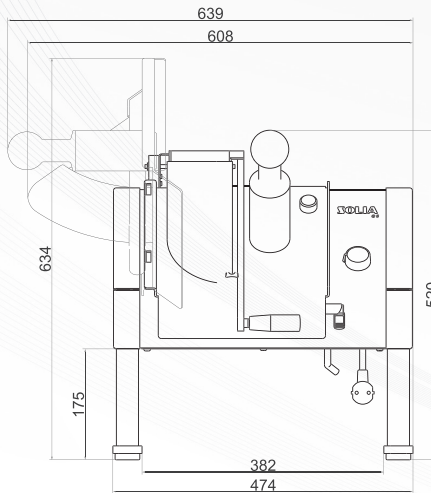

Processing capacity

Description	Use	Throughput**
Curved blade disc, double-bladed	Cutting of vegetables	50 - 200 kg/h
Curved blade disc, single-bladed	Cutting of soft vegetables	50 - 100 kg/h
Crescent blade discs	Cutting of boiled potatoes, leek and mushrooms	80 - 150 kg/h
Strip cutting discs	Strip cutting of e.g. celery, carrots	80 - 150 kg/h
Raw vegetable discs	Shredding of e.g. celery, radish, potatoes, carrots, parmesan	80 - 180 kg/h
Shredding discs	Shredding of e.g. celery, radish, potatoes, carrots, Gouda	120 - 200 kg/h
Grating discs	Grating e.g. bread, nuts, almonds, chocolates, cheese	50 - 120 kg/h
Potato grating disc	Grating e.g. potatoes, parmesan, cheese	50 kg/h
Potato pancake disc	Grating e.g. potatoes	50 kg/h
Dicer	Dicing of vegetables, fruits	120 - 200 kg/h

**The throughputs are dependent on cutting thickness and product.

The figures shown here are for illustration only and may deviate from the actual design version. Technical alterations are reserved. For additional accessories please refer to our price list.
*Items marked with an asterisk are part of the recommended basic equipment.