

m 6

MULTI-PURPOSE KITCHEN MACHINE

GASTRONOMY / CANTEENS



At a glance:

- IP 54 protection, optional IP 65
- Easy-Klick system (stirring bowl)
- entirely in stainless steel (HACCP optimized)
- self-explanatory digital control (with overload protection)
- Modular system (easy to use)
- Optional with universal cabinet and as machine cabinet



One-piece unit for bowl mounting (perfect for processing dough)

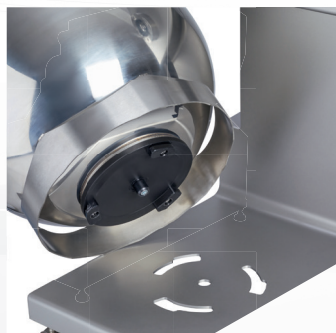

EASY-KLICK System (stirring bowl)



Functional space for GN-containers



XXL filling chute as depot for processing large volumes in one step

Accessories



Universal basic unit, stainless steel
561 000 0311*

Imperative for cutting attachment and diagonal cutting hopper



Cutting attachment with safety switch-off and pusher
104 018 000*

Attention: universal basic unit not included!

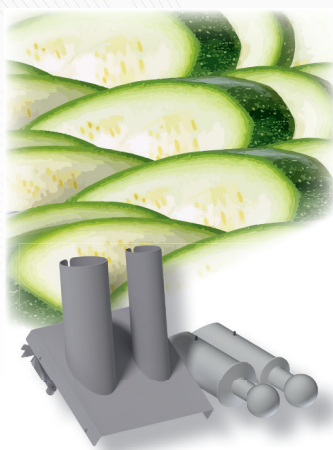

Diagonal cutting hopper with safety switch-off and pusher.
104 019 000

Attention: universal basic unit not included!

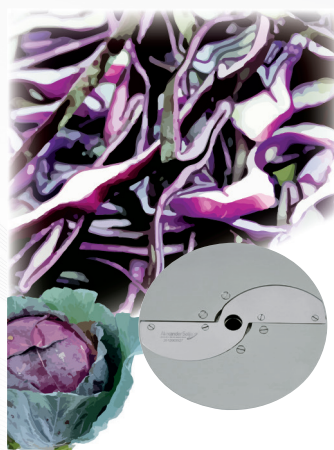

Curved blade disc stainless steel, adjustable double-blade
0 - 5 mm 561 000 0352*

Cutting of e.g. cabbage, cucumber, peppers, onions



Curved blade disc stainless steel, adjustable single-blade
0 - 10 mm 103 275 000

Cutting of soft vegetables



Crescent blade disc, stainless steel
3 mm 561 000 0363
4 mm 561 000 0360*
6 mm 561 000 0361

Cutting of boiled potatoes, leek, mushrooms, soft fruits



Strip cutting discs, stainless steel
2 x 2 mm Juliennes 561 000 0362
4 x 4 mm Juliennes 561 000 0364
6 x 6 mm 561 000 0366
8 x 8 mm 561 000 0368

Strip cutting of carrots, celery, radishes



Crinkle cutting discs, stainless steel
4 mm 561 000 0369
6 mm 561 000 0367

Crinkle cut of red beets, cucumbers, carrots

Accessories



Basic carrier disc, stainless steel for

raw vegetable discs, shredding discs, grating discs, potato grating disc, potato pancake disc

568 000 0370*



Raw vegetable discs, stainless steel, hand sharpened

2 mm 561 000 0380
2,5 mm 561 000 0382
3 mm 561 000 0371*
4 mm 561 000 0374

Shredding of raw vegetables e.g. celery, radish, potatoes, carrots, parmesan



Shredding discs, stainless steel, hand sharpened

6 mm 561 000 0372*
9 mm 561 000 0373

Shredding of vegetables e.g. celery, radish, potatoes, Gouda



Grating discs, stainless steel

2 mm 561 000 0381
3 mm 561 000 0375*
4 mm 561 000 0378

Grating e.g. bread, nuts, almonds, chocolates, cheese,



Potato grating disc, stainless steel, crown-toothed

561 000 0376

Grating e.g. potatoes, parmesan cheese



Potato pancake disc, stainless steel, partly crown-toothed, combination of 376/380

561 000 0377

Grating e.g. potatoes



Dicer, complete, stainless steel

4 x 4 x 5 mm 103 240 100
5,5 x 5,5 x 5 mm 103 243 100
8 x 8 x 10 mm 103 246 100
11 x 11 x 10 mm 103 250 100
16 x 16 x 10 mm 103 252 100
22 x 22 x 10 mm 103 255 100



Protective hand grip for dicer disc

105 040 190

Cleaning Brush

1500876

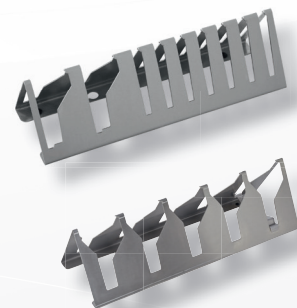

Multi disc rack, stainless steel, for 2 discs and 7 exchange discs

561 000 0191*

Disc rack, for 5 discs

561 000 0190

Accessories



Planetary stirring, beating and kneading unit 15 l
106 035 000*

Composed of: planetary mixer head, stirring bowl 15 l, covering hood 15 l, beating whisk, stirring whisk and kneader



Beating whisk, stainless steel
15 l 561 000 0232



Stirring whisk, stainless steel
15 l 561 000 0242



Kneader, stainless steel
15 l 561 000 0265



Meat und vegetable mincer 70 mm with safety switch-off

104 045 000*



Composed of:
meat tray, pusher, mincer housing, worm, 3-part cutting set, coded, stainless steel, L&W.

Incl.: pre-cutter, 4-wing knife, coded perforated disc 4 mm, spacer ring 13 mm.

Accessories



**Universal housing for strip cutter,
steaker and meat tenderizer**
104 025 101

Composed of:
stainless steel housing and coupling M 6.
Attention: To be ordered together with strip cutter
set and/or tenderizer/steaker set.



Strip cutter set
104 025 100
Safety switch-off in accordance
with EU standard

Composed of: complete lid incl. funnel,
magnet holder and pusher.
Attention: universal housing as well as the
resp. inserts are not included.



Cutting inserts, stainless steel

3,3 mm	15 00 727
5,0 mm	15 00 728
6,6 mm	15 00 729
9,9 mm	15 00 730
19,8 mm	15 00 731

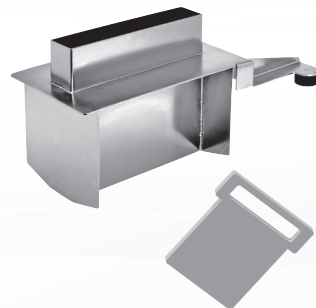

Steaker/meat tenderizer Set
104 027 100

Composed of: feed chute, pusher and magnet
holder.
Attention: universal housing as well as the
resp. inserts are not included.



Steaker insert
15 00 732

Meat tenderizer insert
15 00 733

Technical data



M 6 multi-purpose kitchen machine

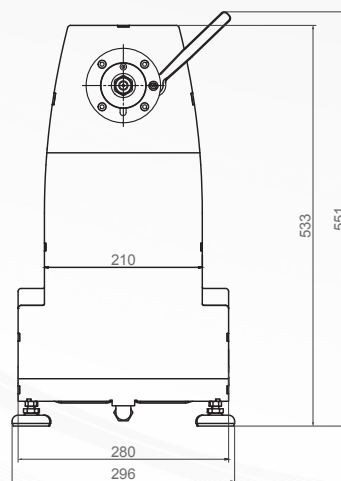
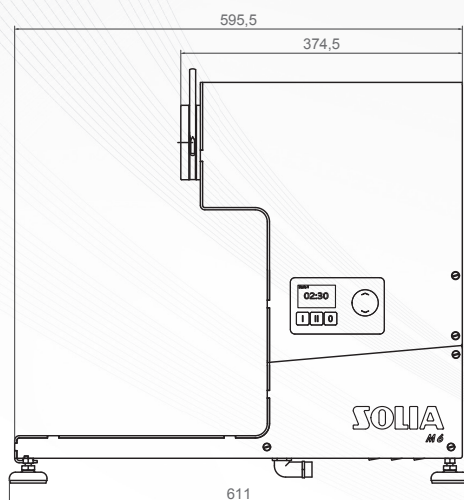

Technical data

Power supply	400 V, 50 Hz 3 m cable with CEE plug 5-p
Output (kW)	0,5 / 0,7
Fuse protection (A)	16
Ingress protection	IP 54 (splash-proof) / optional IP 65
Infinitely variable speed control (rpm)min	160 / 320
Dimensions (L x W x H)	296 x 611 x 553 mm
Weight (kg)	28

Processing capacity

Description	Use	Throughput**
Curved blade disc, double-bladed	Cutting of vegetables	50 - 200 kg/h
Curved blade disc, single-bladed	Cutting of soft vegetables	50 - 100 kg/h
Crescent blade discs, stainless steel	Cutting of boiled potatoes, leek and mushrooms	80 - 150 kg/h
Strip cutting discs	Strip cut of e.g. celery, carrots	80 - 150 kg/h
Raw vegetable discs	Shredding of e.g. celery, radishes, potatoes, carrots, parmesan	80 - 180 kg/h
Shredding discs	Shredding of e.g. celery, radish, potatoes, carrots, gouda cheese	120 - 200 kg/h
Grating discs	Grating e.g. bread, nuts, almonds, chocolates, cheese	50 - 120 kg/h
Potato grating disc	Grating e.g. potatoes, parmesan cheese	50 kg/h
Potato pancake disc	Grating e.g. potatoes	50 kg/h
Dicer	Dicing of vegetables, fruits	120 - 200 kg/h

** The throughputs are dependent on cutting thickness and product.

The figures shown here are for illustration only and may deviate from the actual design version. Technical alterations are reserved. For additional accessories please refer to our price list.
*Items marked with an asterisk are part of the recommended basic equipment.